



TKM BT82 Engine Homologation Fiche BT820394

Effective: January 1st 2021

Created 03/1994 incorporating all Extensions & Amendments to Date

Note: All amendments/changes from last year to this year are highlighted in YELLOW

As Agreed with Motorsport UK



Tal-Ko is committed to manufacturing and supplying high quality components, and to maintaining equality of the TKM BT82 kart engines. We reserve the right to amend detail specification and manufacturing techniques in line with our commitment to constantly monitoring and improving quality and reliability.

Tal-Ko manufacture a complete range of officially sanctioned and part numbered TKM gauges and measurement devices which should always be used when checking engine measurements. In the case of any doubt or dispute, **only** these approved items must be used and the results taken as definitive and final. Full details are given in Appendix 1 on pages 17 & 18 in this engine fiche. **New** engines out of the box will comply with this fiche.

Tal-Ko cannot be held responsible if your **used** TKM BT82 engine does not comply with this Fiche. This can occur due to carbon build up on the piston and to changes made to the engine by anyone rebuilding. We strongly advise all users to check that engine does comply with Fiche before entering a race meeting. Fiche checking should take place frequently, especially after engine has been serviced or run for a period of time.

Please Note: It is vital that the BT82 engine is run in accordance with our installation & running guide. We recommended it is run on standard 95 unleaded pump fuel at a ratio of 5 litres of fuel to 320ml of Shell Advanced Racing M Castor Based Oil which must be thoroughly mixed before use.

Please Note: The engine and any other measuring test equipment used should be at a cold (ambient) temperature of between -5C and +50C. Any readings taken within this temperature span will be accepted as definitive.

For the avoidance of doubt, where dimensions and tolerances are stated in this official TKM BT82 engine fiche these are for information only and it is stressed that unless specifically stated as permissible, it is **NOT** permitted to alter any component to the fiche dimensions.

Where components are found to be in breach of regulations and not capable of being rectified they may be marked prominently and permanently as such by Tal-Ko.

TKM BT82 Engine Fiche BT820394 Incorporating all Extensions & Amendments

Effective JAN 1st 2021

DIRECT DRIVE ENGINE SIDE FRONT



V CLUTCH ENGINE SIDE FRONT



DIRECT DRIVE ENGINE SIDE REAR

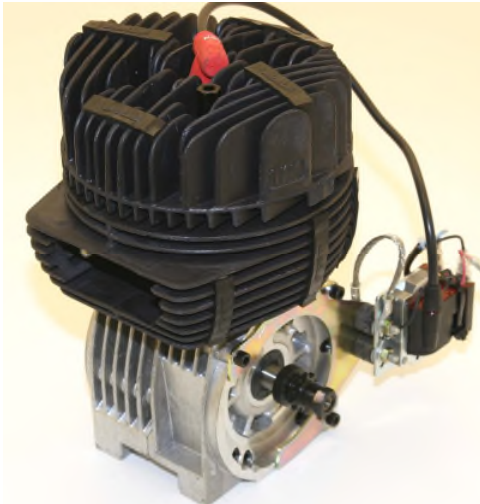

V CLUTCH ENGINE SIDE REAR



TOP OF ENGINE

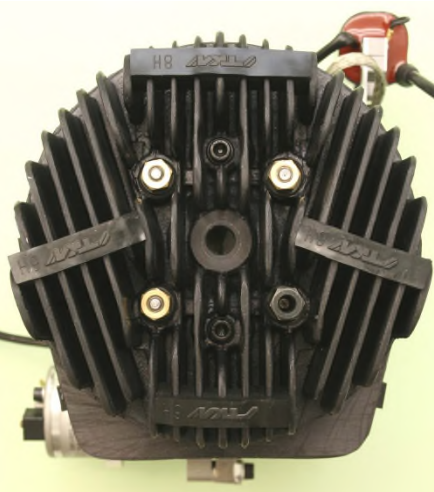

CYLINDER HEAD INTERNAL



CYLINDER BARREL BASE



NEW STYLE CRANKCASE TOP

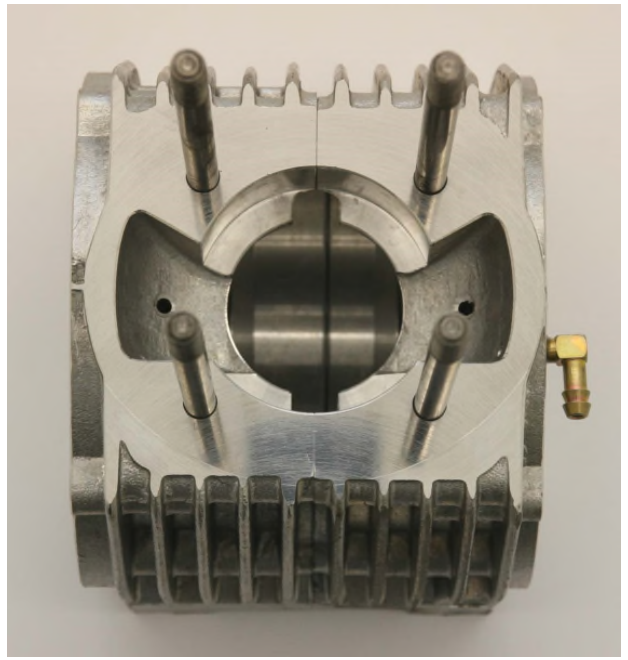

NEW STYLE CRANKCASE INTERNAL

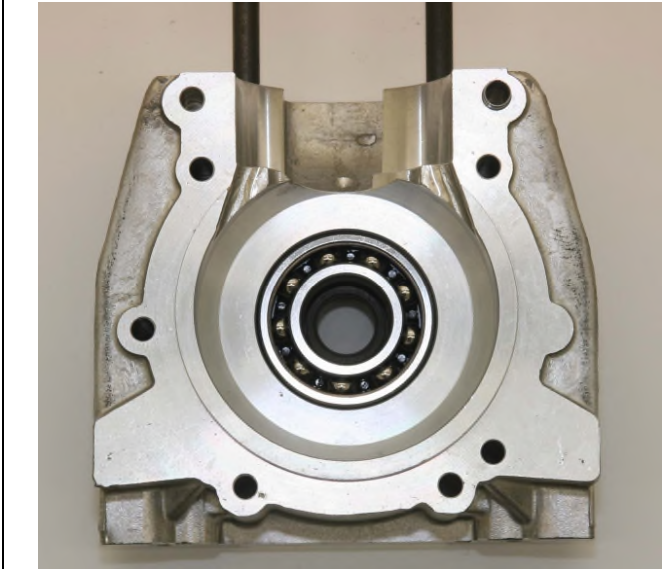

CON-ROD



HORSTMAN TKM CLUTCH

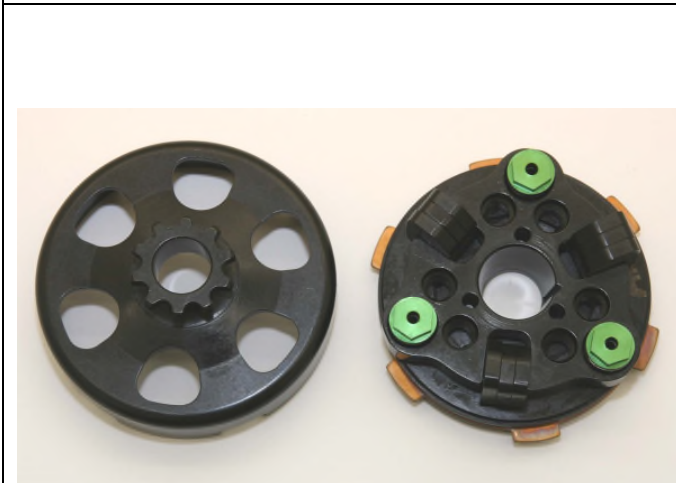

V CLUTCH



See Page 7 for new type Clutch Drum & Clutch Springs

CARB SPACER BLOCK



TKM HEAD GAUGES



TKM PORT FEELER GAUGER



TKM INDUCTION BOX



TKM FILTER & CARB FLANGE



TKM LOGO ON CYLINDER LINER

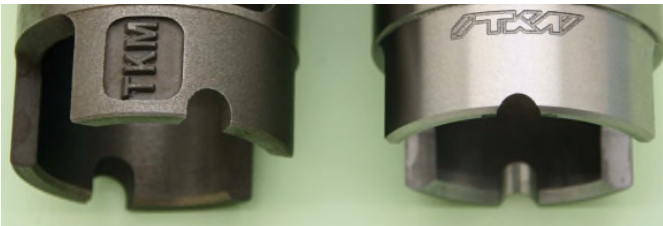

OLD STYLE CAST

NEW STYLE CNC MACHINED

CRANKCASE OLD STYLE



CARB RESTRICTOR PLATES



CRANKSHAFT HALVES



Old style Direct Drive with 20mm Bearing
 New style Direct Drive with 25mm Bearing
 Old style Horstman with 20mm Bearing

CRANKSHAFT INTERNAL FACE

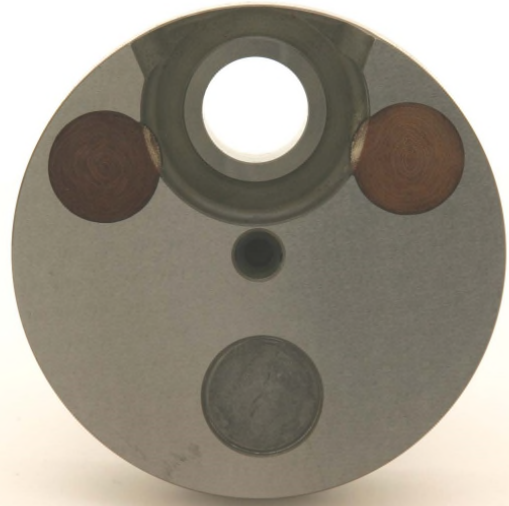

TUFNOL Stuffer X 2 at top and LEAD Stuffer X 1 at bottom

TAG ENGINE DRIVE SIDE











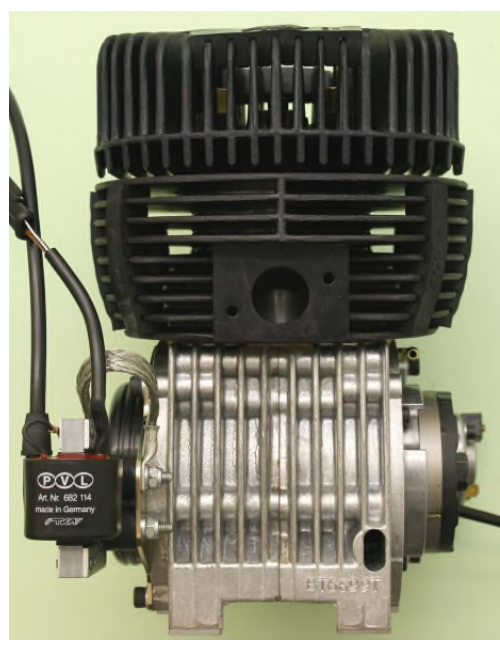
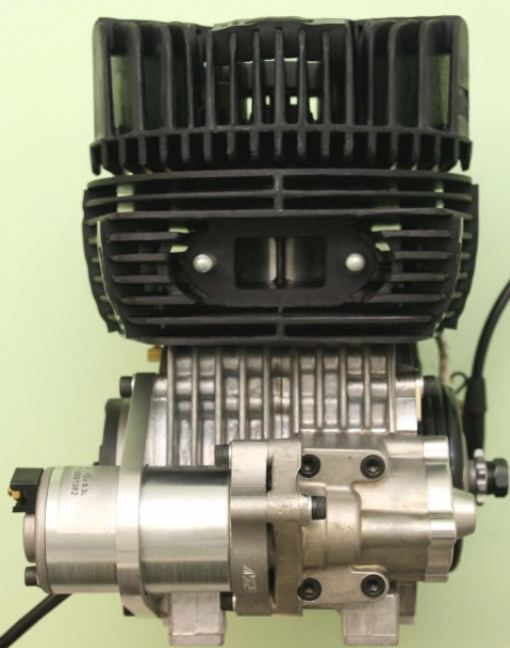

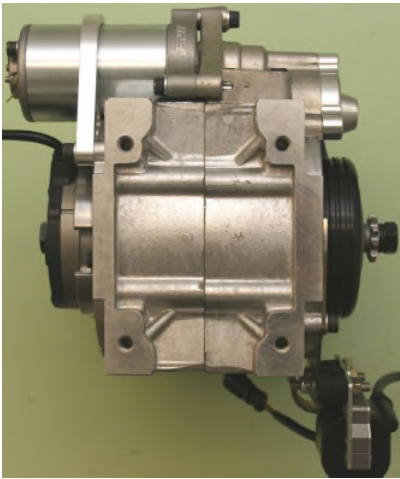
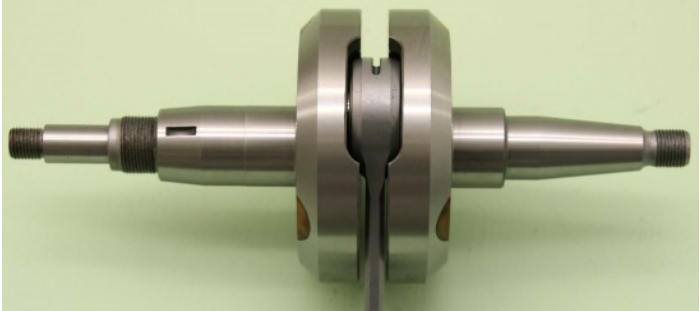
TAG ENGINE FROM THE BACK

TAG ENGINE IGNITION SIDE





TAG ENGINE FROM THE FRONT







TAG ENGINE FROM THE BOTTOM		TAG CRANKSHAFT	
			
TAG STARTER MOTOR		TAG STARTER MOTOR BENDIX	
			
<p>TAG PVL CDI BOX P/N 682 242</p>	<p>TAG PVL COIL P/N 682 114</p>	<p>TAG PVL STATOR P/N 682 810</p>	<p>TAG PVL ROTOR P/N 682 900</p>
			
TAG PVL IGNITION MODULE P/N 683 150 (NEW STYLE)		<p>TAG PVL STATOR P/N 683 850 (NEW STYLE)</p>	<p>TAG PVL ROTOR P/N 683 900 (NEW STYLE)</p>
			

BT820394



OLD TYPE V CLUTCH DRUM	NEW TYPE V CLUTCH DRUM
	

A new style V Clutch drum becomes a standard fitment on all new TAG and V Clutched specification engines. The new V Clutch drum may also be used on existing TAG and V Clutched engines of any age. Both versions of the drum are permitted.

OLD TYPE WALBRO CARB GASKET	NEW TYPE WALBRO CARB GASKET
	

OLD TYPE CARB FLANGE GASKET	NEW TYPE CARB FLANGE GASKET
	

New material gaskets for both the Walbro carb and Walbro carb flange are standard fitment on all new engines. They may be used on engines of any age. Other gaskets used on the engine will also be superseded with new material or design as and when required.

OLD TYPE CLUTCH SPRING (YELLOW x 2.2mm)	NEW TYPE CLUTCH SPRING (GREEN x 2.3mm)
	

A new stronger green coloured V Clutch spring is standard fitment on all new TAG and V Clutched specification engines. The new V Clutch spring may also be used on existing TAG and V Clutched engines of any age. Both versions of the springs are permitted.

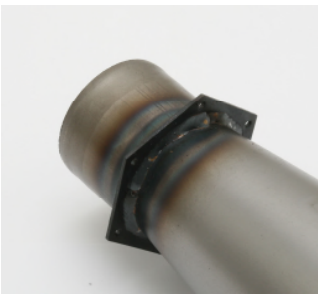
OLD TYPE TAG EXHAUST PIPE FLEX FLANGE	NEW TYPE TAG EXHAUST PIPE FLEX FLANGE
	

Both versions of Tag exhaust with these flex flanges are permitted

TKM BT82 Engine Fiche BT820394 Incorporating all Extensions & Amendments

ENGINE	MAX BORE SIZE	PISTON RANGE	STROKE
All 100cc	51.45 mm	50.6 – 51.4 mm	48.5 mm
All 115cc	54.80 mm	54.25 – 54.75 mm	48.5 mm

When measuring and checking for the maximum permitted piston bore size in the cylinder barrel, the bore may be measured at any position within its full length where the circumference is continuous – i.e. not where there are port openings or con rod clearance cut outs. **If the maximum permitted bore size is exceeded at any point then the cylinder barrel is illegal.** The cylinder piston bore must be nominally perpendicular to the cylinder base and central to the cylinder liner. Out of centre and/or angled cylinder piston bores are not permitted.

PISTON ASSEMBLY: Material: Aluminium. Must be as supplied for engine and manufactured by or for Tal-Ko with no modifications, machining or added coatings allowed. Must have the name TKM cast on its internal. Carbon removal from piston crown must not alter or change piston. Piston rings must at all times remain predominately free (50% or more) to operate in the manner in which they were designed and supplied. It is the responsibility of the driver to ensure that the rings are not 'coked' in place with carbon or prevented from their normal 'spring' effect by other methods. The piston rings must be appropriate to the piston size used and have a maximum ring gap of 0.5mm when measured with the ring placed squarely 5-10mm down from the top of the cylinder bore. Only the standard unmodified earless type piston cir-clips as supplied by Tal-Ko must be used. The Extreme 115cc engine uses one piston ring; the Junior 100cc engine may use one or two piston rings. The bottom piston ring for the Junior 100cc engine can be removed for racing if required. The top piston ring for both the Junior 100cc & Extreme 115cc engine must remain in place for racing at all times.

The following dimensions must comply:-

ITEM	ANGLE Degrees	SIZE MM	ENGINE
Overall Height from Centre of Crown to Bottom of Piston	N/A	58.54 (+ - 0.1)	All 100cc & 115cc
Dimension from Bottom of Piston to Top Ring Lower Face	N/A	51.90 (+ - 0.1)	All 100cc
Dimension from Bottom of Piston to Top Single Ring Lower Face	N/A	51.70 (+ - 0.1)	All 115cc
Chamfer Size on Bottom of Piston on O/D	N/A	0.5 MAX	All 100cc & 115cc
Number of Piston Rings	N/A	1 or 2	All 100cc
Number of Piston Rings	N/A	1	All 115cc
Range of Piston Sizes	N/A	50.60 to 51.40	All 100cc
Range of Piston Sizes	N/A	54.25 to 54.75	All 115cc
Piston Crown Angle	10 (+0.7 - 0.4)	N/A	All 100cc & 115cc

PISTON DRAWING

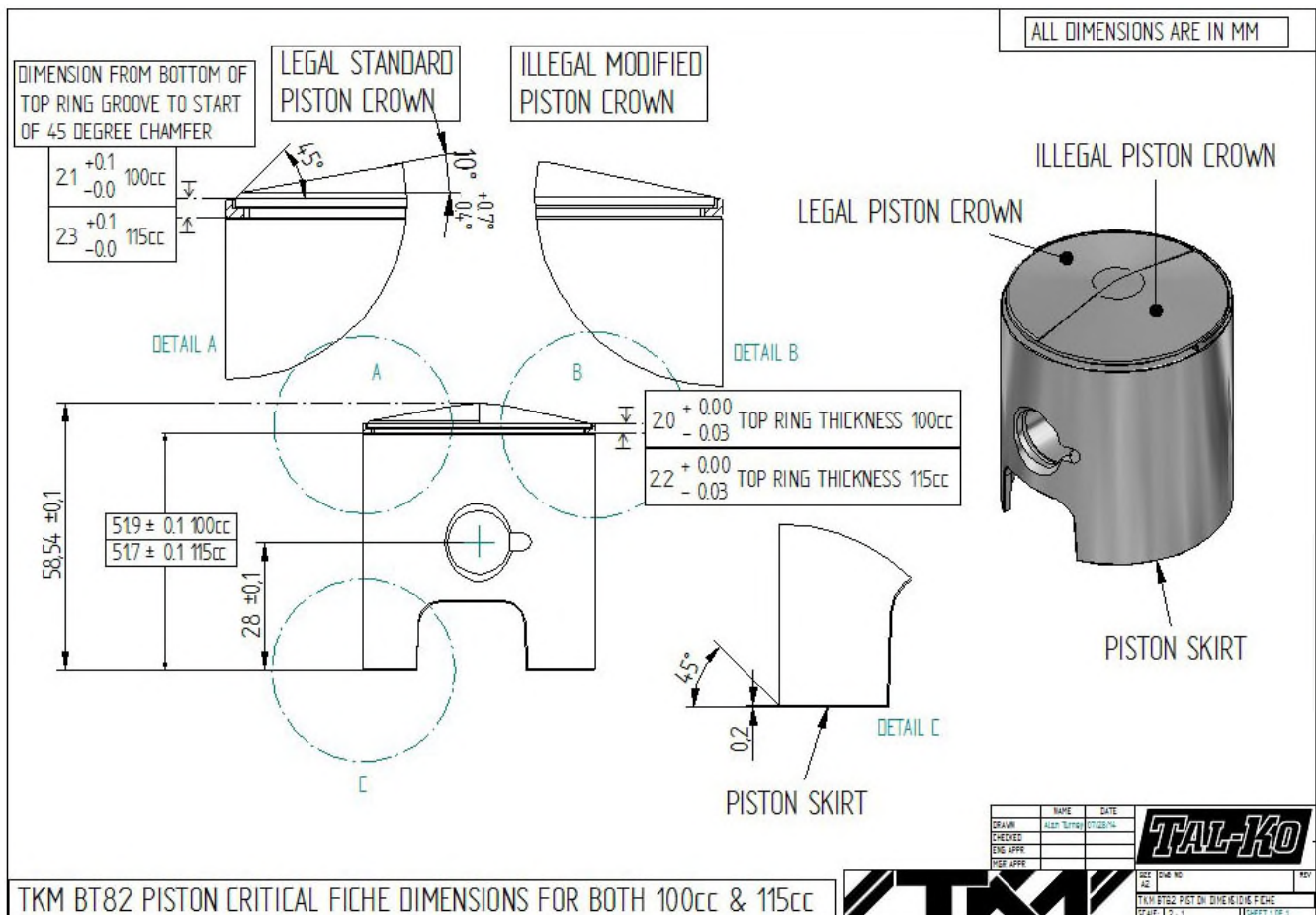

BT820394

CON-ROD: Material: Steel. No modifications allowed. Must be as supplied for engine and manufactured by or for Tal-Ko with no modifications allowed & stamped/marked with TKM logo.

The following dimensions must comply:-

ITEM	DIMENSIONS / WEIGHT	ENGINE
Weight	114 Grams + - 6 Grams	All 100cc & 115cc
Length between Centres of S/E & B/E	96mm + - 0.1mm	All 100cc & 115cc
Width of S/E & B/E	14mm Nominal	All 100cc & 115cc
B/E I/D	24mm Nominal	All 100cc & 115cc
S/E I/D	18mm Nominal	All 100cc & 115cc

CRANKSHAFTS: Material: Steel. Must be as supplied for engine and manufactured by or for Tal-Ko with no modifications or additional balancing allowed. Must have BT82 etched on flywheel O/D's. The balance inserts must always be in their place and of their original size, appearance, weight and material. Reducing the crank bearing journals and oil seal shaft sizes by grinding is expressly forbidden.

ITEM	SIZE MM
Permitted Width of Crank Faces when assembled	44.0 + - 0.1
O/D of Crank Flywheels	84.0 O/D Nominal
Width of Crank Flywheels	18.0 Nominal

CRANK BIG END PIN & PISTON SMALL END PIN: Material: Steel. Must be as supplied for engine and manufactured by or for Tal-Ko. No stuffing or modifications allowed.

Only the following TKM B/E & S/E pins allowed:-

ITEM	DIMENSIONS MM	ENGINE
Big End Crank Pin (Hollow Type)	18 O/D X 44 Long with 6.4 to 8.6 Straight Bore	100cc & 115cc
Big End Crank Pin (Alternative Solid Type H/D)	18 O/D X 44 Long with 9.5 x 9 Bored Domed Ends	100cc & 115cc
Small End Gudgeon Pin	14 O/D X 42 Long with 10.2 Max Bore	100cc
Small End Gudgeon Pin	14 O/D X 44 Long with 10.2 Max Bore	115cc

MAIN CRANK BEARING: On new style crankcase the main crankshaft bearing size increases from 20mm I/D X 47mm O/D X 14mm wide to 25mm I/D X 52mm O/D X 15mm wide. Tal-Ko manufactured brass main bearing shims may be used to facilitate correct crankshaft end float clearance. Ceramic type bearings may not be used in the engine. Only the FAG bearings listed below are permitted with no modifications or additions. Increasing the crank bearing journal bore size by honing or grinding is expressly forbidden.

BEARING TYPE	SIZE MM
FAG 6204 TVH C4	20 I/D x 47 O/D x 14 Wide
FAG 6205 TVH C4	25 I/D x 52 O/D x 15 Wide

SMALL END BEARING ASSEMBLY: Must be as supplied for engine and manufactured by or for Tal-Ko with no modifications allowed. Consists of 25 loose rollers with either 2 x 1.0mm thick steel washers plus 2 x 1.85mm thick aluminium washers or with just 2 x 2.85mm thick steel washers.

BIG END BEARING ASSEMBLY: Only the NIPPON THOMPSON 15 caged roller bearing permitted.

CRANK OIL SEALS: Must be ROLF or TTO manufacture, type and size as originally supplied by Tal-Ko with engine. Only the following oil seals permitted with no modifications:-

OIL SEAL TYPE	SIZE MM	MODEL
ROLF RP	18 I/D x 32 O/D x 8 Wide	Direct Drive Old 20mm Bearing Crank
ROLF RP	20 I/D x 32 O/D x 7 Wide	Horstman Clutch Old 20mm Bearing Crank
TTO TCWJ (Teflon Lip)	18 I/D x 35 O/D x 7 Wide	Direct Drive New 25mm Bearing Crank
TTO TCWJ (Teflon Lip)	20 I/D x 35 O/D x 7 Wide	TAG Ignition Crank
TTO TCWJ (Teflon Lip)	25 I/D x 35 O/D x 7 Wide	V Clutch Crank

GASKETS: Only original TKM gaskets are permitted. No head gaskets allowed. The use of only one gasket on all mating faces is allowed. The only exception to this is the barrel to crankcase mating face where it is only permitted to use up to a total of any three of the standard 3 alternative thickness (0.25mm, 0.4mm & 0.5mm) TKM stamped supplied gaskets, providing the exhaust and inlet port positions still comply with Fiche. There are now three thickness of crankcase gaskets allowed (0.25mm, 0.4mm & 0.5mm). The use of any substance or material to replace the using of any gasket is not permitted. Use of gasket sealer/grease is permitted. Other gaskets used on the engine will also be superseded with new material or design as and when required.

CRANKCASE: Material: Aluminium. Must be as supplied for engine and manufactured by or for Tal-Ko with no modifications allowed. Port passages must remain as cast. All mating faces must not be subject to remachining or dressing. Additional drilling and tapping for any reason is not permitted. 90 degree pulse elbow must not be modified. New style crank has bigger main bearings and different external appearance. On new style crankcase the engine mounting bolt pattern changes from 80mm X 123mm to 80mm X 102mm. These dimensions are bolt centre line dimensions. Permitted dimension from centre line of crankshaft to barrel mating face is **68.1mm to 68.2mm** on both the old and new style crankcase. New style crankcases now have extra lightening holes and pockets around centre gasket face area and TAG crankcases now have additional air cooling holes/slots on ignition side. It is not permitted to machine crankcase bearing or oil seal bores to accept refurbishment sleeves to correct worn bearing and oil seal bores.

CYLINDER BARREL: Material: Aluminium. Must be as supplied for engine and manufactured by or for Tal-Ko with no modifications allowed. Must be black anodised in total and have Tal-Ko Motori cast on its bottom fin. Black anodising must be present in all port passages. Re-anodising or painting is not permitted. Base, inlet & exhaust faces must not be remachined or dressed. Carbon removal in exhaust port must not damage black anodising.

INLET PORT OPENING: 21.90mm ATDC MAXIMUM (All 100cc & 115cc engines)

Using zeroed dial and 0.25mm TKM P/N TFG025 feeler gauge method, then insert feeler gauge from front of engine into piston bore, holding it against bottom of inlet port floor. Turn crank until bottom of piston makes gentle contact with feeler gauge. Opening measurement is now taken directly from dial gauge ignoring feeler gauge thickness. **Please Note:** When measuring the inlet and exhaust port timing it is clarified that the maximum contact pressure on the TKM P/N TFG025 feeler gauge should be only that achieved through finger & thumb pressure on either one of the crank nuts. The dial gauge and fixture block used for this purpose must be tightened down at 13lb/ft on each of the two nuts. The nuts/studs must have threads in good condition, lubricated, and with nuts which can be easily moved by finger-only pressure at the point of being tightened.

EXHAUST PORT OPENING: 28.5mm ATDC MINIMUM (All 100cc & 115cc engines)

Check with dial indicator, fixture block and 0.25mm thick X 6mm parallel nominal width TKM P/N TFG025 feeler gauge, the piston travel from Top Dead Centre (TDC) to exhaust opening. After zeroing dial at TDC, turn crank until exhaust is open approx 4mm. Insert feeler gauge from back of engine into piston bore, holding it against top of exhaust port roof close to the piston. Turn crank until top of piston makes gentle contact with feeler gauge. Opening measurement is now taken directly from dial gauge, ignoring feeler gauge thickness.

INLET TRACT LENGTH: 67mm MINIMUM on all 100cc engines and **65mm MINIMUM** on all 115cc engines. This measurement is taken from carb mating face on spacer block to piston less all gaskets and restrictor plates.

CARB SPACER BLOCK: Must be as supplied for engine and manufactured by or for Tal-Ko with no modifications allowed. Must have the TKM logo. Throttle cable hole may be enlarged and slotted. Carb spacer bore **26.4mm MAXIMUM**

CARBURETTOR: Must be a standard WALBRO WB-19 with TKM logo present on front face of carb. No modification allowed. One carburettor only. An extended high jet is permitted providing the original jet is still used and does not exceed 50mm in length. It is not permissible to extend the low jet. You may modify the slot in the swivel assembly for ease of throttle cable fitment. The small butterfly adjustment screw and spring which sets tickover can be fitted either way round. Only genuine WALBRO WB19 replacement spare parts permitted. No additional fuel pumps allowed.

CARB RESTRICTOR PLATE:- For the TKM classes that use a single TKM manufactured anodised carb restrictor plate of various inlet hole sizes between the carburettor and engine. It must be a flat aluminium metal plate with a nominal minimum thickness of 3mm and a central parallel round bore of varying sizes and identifying colours according to driver weight / class through which all the mixture feeding the engine must pass. No blenders of any configurations are allowed. This restrictor plate must not be modified or polished in any way and must be as supplied for engine and manufactured by or for Tal-Ko with no modifications allowed. It must display the genuine TKM logo. Coloured anodising must be intact.

SPARK PLUGS: For all engines it is mandatory to use the appropriate HT lead, spark plug cap and approved spark plug (with its original sealing gasket washer in place) all in unmodified form. Note for TAG engines the plug cap is PVL and black in colour and for non-TAG it is NGK and red in colour. The HT leads are also different and not interchangeable between TAG and non-TAG engines.

The only spark plugs permitted are:

DENSO – W27ES-ZU, W31ES-ZU, IW27 and IW 31

NGK – B9EG, B10EG, BR9EG, BR10EG, B9EGV, B10EGV, BR9EIX and BR10EIX.

CYLINDER LINER: Material: Cast Iron. Must be as supplied for engine and manufactured by or for Tal-Ko with TKM logo. No modifications, surface added coatings and/or treatments or plasma metal spraying allowed unless specifically authorised in this BT82 engine fiche and/or TKM regulations. Must either have cast ports throughout as on original old style liners or fully CNC machined ports throughout as on new style liners. The new style liners are easy to identify because when the liner is placed in the upright position as it would be fitted on an engine the TKM logo is now machined in a horizontal position rather than cast in a vertical position. The new style manufactured liner with machined ports complies with exactly the same fiche dimensions as on the previous type. New style liners complete with barrel may be fitted to an older engine. Similarly old style liners/barrels may be fitted to a new type engine. It is not permitted to remove a liner from its barrel, and the original unmodified liner locking pin must always be in its position. Only the head mating face can be machined and it is permitted to re-bore and hone to all listed piston sizes.

Cylinder Liner Port Measuring Gauges

Tal-Ko offers a range of gauges for measuring the internal ports in the cylinder liner of the TKM BT82 engine. All gauges are manufactured to a high level of accuracy and all carry the TKM logo together with a part number to verify their consistency. Gauges should be inserted into the barrel either from above or below as appropriate and must be used at right angles to the dimension being checked. All are 'No Go' gauges. It is recommended that the engine is allowed to cool and barrel removed before testing with gauges. The barrel should be between -5C & +50C at time of testing. No Go readings taken at any point within this temperature scale will be acceptable and definitive.

Please note: Exhaust Port height gauge P/N 4EH is now obsolete and is superseded with a new Exhaust Port height gauge P/N 4EHN. There are now two Inlet Port height gauges. The old Inlet Port height gauge P/N 7IH is for the old type CAST port liners and the new Inlet Port height gauge P/N 7IHCNC is for the CNC machined port liners.

The following port dimensions of liner measured in bore using official TKM port gauges as listed must comply:-

ITEM	CHORD WIDTH MM	GAUGE	HEIGHT MM	GAUGE
Inlet CAST Port	33.90 MAX	P/N 6IW	22.55 MAX	P/N 7IH
Inlet CNC Port	33.90 MAX	P/N 6IW	22.32 MAX	P/N 7IHCNC
Exhaust Port	39.90 MAX Total width of both	P/N 3EW	21.06 MAX	P/N 4EHN
Exhaust Bar	4.80 MIN	P/N 5EB	N/A	N/A
Transfer Big	20.25 MAX	P/N 8TW	N/A	N/A
Transfer Small	13.00 MAX	P/N 9TW	N/A	N/A

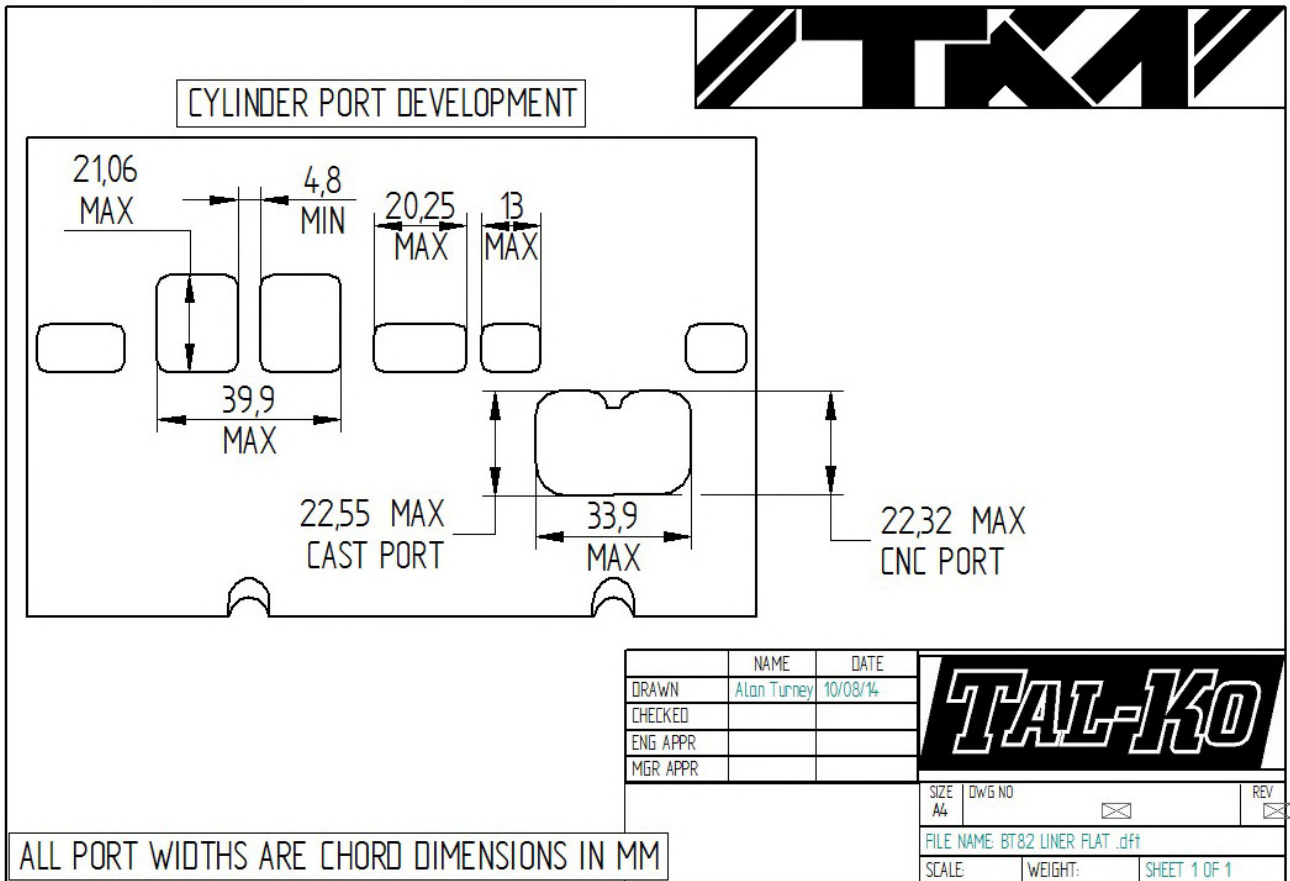

CYLINDER HEAD: Material: Aluminium. Must be as supplied for engine and manufactured by or for Tal-Ko. Must remain black anodised externally. Re-anodising or painting is not permitted. Its combustion chamber shape must be spherical and have a squish band. Any machining of the head or liner to accept a sealing device is not allowed. The machining of combustion chamber, liner mating surface and its locating shoulder is permitted providing shape and head volume remain within limits. The cylinder head and/or liner mating face(s) must always remain flat over the full extent of their original surface. A minimal amount of machining is permitted to the cylinder head subject to stringent conditions, primarily intended to allow rectification of engines that have suffered head damage. This must be carried out in line with the drawings laid out in the fiche. Note that the squish angle face of 12 degrees plus or minus 1 degree must meet and intersect the liner mating face of the cylinder head at that angle, with no intermediary angles or curves throughout their full circumference. Any form of step, recess, groove or similar will render the cylinder head illegal since it will not follow the original shape.

The combustion chamber dome must at all times remain as a concave spherical shape throughout its entire diameter. At the point where it meets the squish band there must be only one nominal radius which must be a maximum of 3mm.

We clarify that any fundamental shape change to the concave spherical dome introducing convex spherical shaping, more than one intermediary angle or radius at the point of meeting the squish band, or any change which makes its shape outside that stated, will render the cylinder head illegal. It is not permitted to add material of any kind to change dimensions or alter shape of the combustion chamber, machined faces or any other area.

CYLINDER HEAD VOLUME: Use official TKM measuring plug P/N 003

<i>ENGINE</i>	<i>ENGINE Fitted with EeziStart</i>	<i>GLASS BURETTE</i>	<i>DIGITAL BURETTE</i>
Jnr 100cc	Jnr 100cc	Burette: 11.0cc Min	Digital: 10.6cc Min
Snr & Jnr Extreme 115cc	Snr & Jnr Extreme 115cc	Burette: 12.0cc Min	Digital: 11.6cc Min
TAG Jnr 100cc	N/A	Burette: 10.0cc Min	Digital: 9.6cc Min
TAG Snr & Jnr Extreme 115cc	N/A	Burette: 11.0cc Min	Digital: 10.6cc Min

When taking measurement of the cylinder head volume, the cylinder head must be fitted to the engine in the manufacturer’s normal manner with the standard brass head nuts & TKM sealing nut tightened to 13lb/ft and the two small cap headed bolts tightened to 8lb/ft. The nuts/studs must have threads in good condition, lubricated, and with nuts which can be easily moved by finger & thumb-only pressure at the point of being tightened. If the engine is fitted with the optional EeziStart De-Comp valve then this must be in the fully closed position and tightened to 13lbs/ft. The engine must be as raced - e.g. with the same gaskets in position and with no carbon removed from the top of the piston, inside of the combustion chamber, etc. The cylinder head may be removed for inspection by an authorised Motorsport UK scrutineer before being replaced for a head volume check. Greasing of top & bottom ring is not permitted. When carrying out such a check use must be made of the authorised and TKM marked measuring plug P/N 003 ensuring that it is fully tightened down on plug washer face to 13lbs/ft. The engine must be in an upright stable position. The piston must be at Top Dead Centre.

An ‘A’ grade burette or digital burette should be used with light grade oil which meets the specification:-

Viscosity: 61 Centistokes at 20 Degrees C which is available from Tal-Ko.

It is recommended that the measuring oil should be inserted into the engine within a period of two minutes. Once it is determined that the oil level has reached the top of the measuring plug hole, the reading should be taken within 30 seconds with no more oil added. Note that the definitive measurement is the one taken with the measuring plug. Because of the variation in measurement systems, the results of volume checks will vary dependent on the type of system used – standard burette or digital burette.

CYLINDER HEAD COMBUSTION CHAMBER SHAPE LIMIT: (See head drawings and photos)

Use official TKM head gauges in the list below to check if head complies:-

<i>HEAD GAUGE</i>	<i>CHECKS</i>	<i>ENGINE TYPE</i>
P/N 001	Dome Size / Squish Angle / Squish Diameter / Plug Washer Face	All 100cc
P/N 001/11	Squish Angle Minimum Permitted 11 Degree	All 100cc
P/N 001/13	Squish Angle Maximum Permitted 13 Degree	All 100cc
P/N 001/E	Dome Size / Squish Angle / Squish Diameter / Plug Washer Face	All 115cc Extreme
P/N 002	Depth of Dome / Plug Washer Face	All 100cc & 115cc
P/N T004	Radius Size between Dome and Squish Band	All 100cc & 115cc

The following findings will make head illegal:-

- 1) If there is more than a 1.0mm max gap between dome part of gauge P/N 001 and actual dome of combustion chamber on all 100cc model engines in any position.
- 2) If there is more than a 1.6mm max gap between dome part of gauge P/N 001/E and actual dome of combustion chamber on all 115cc model engines in any position.

BT820394

- 3) If the gauge P/N 001 protrudes out past spark plug washer face on all 100cc models.
- 4) If the gauge P/N 001/E protrudes out past spark plug washer face on all 115cc models.
- 5) If gauge P/N 002 protrudes down past last spark plug thread into dome on all 100cc & 115cc models.
- 6) If squish angle, squish diameter or radius between dome and squish band is outside their permitted tolerance using gauge P/N 001, P/N 001/11 & P/N 001/13 for all 100cc models and P/N 001/E for all 115cc models.
- 7) If the radius between dome and squish band using gauge P/N T004 is larger than permitted 3mm Max Radius.
- 8) If at the point where the dome meets the squish band there is more than one nominal radius.
- 9) If the combustion chamber dome does not at all times remain as a concave spherical shape throughout its entire diameter.

Cylinder Head combustion chamber shape limits:-

ITEM	LIMIT	ENGINE TYPE
Squish Diameter	51.70mm MAX DIA	All 100cc
Squish Diameter	55.05mm MAX DIA	All 115cc
Squish Angle	12 DEGREES + - 1 DEGREE	All 100cc & 115cc
Radius between Dome and Squish Band	3.0mm MAX RAD	All 100cc & 115cc
Gap between Dome and Dome Gauge	1.0mm MAX	All 100cc
Gap between Dome and Dome Gauge	1.6mm MAX	All 115cc

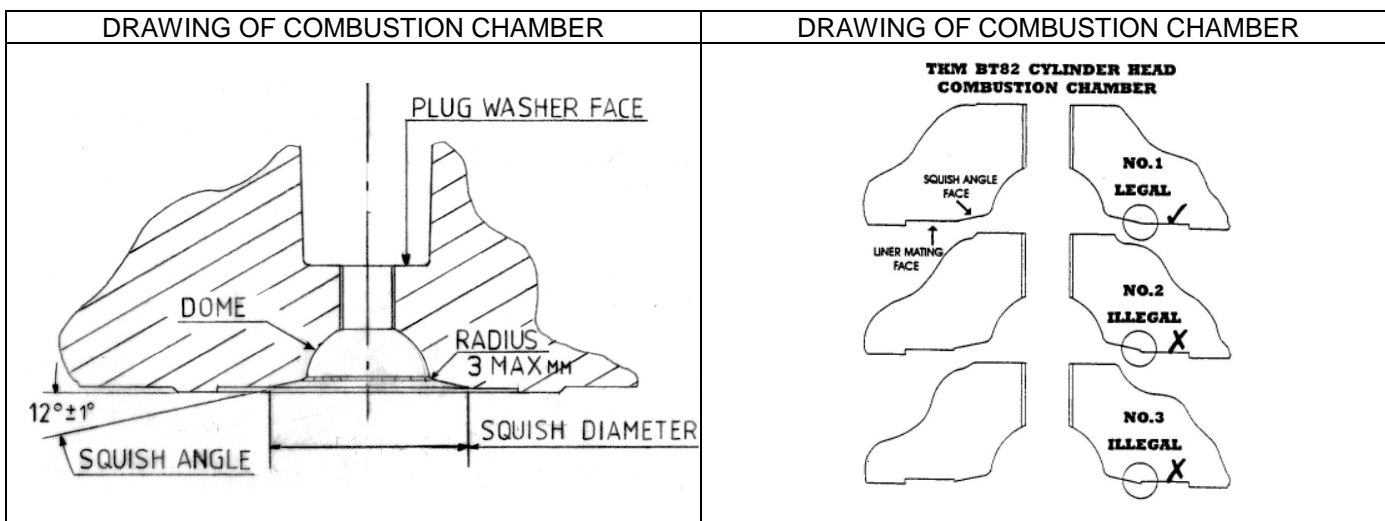

EEZISTART DE-COMPRESSION VALVE: It is permitted to use the optional EeziStart De-Comp valve on all models of the TKM BT82 engines except the TAG option. It must be as supplied for the engine by Tal-Ko with no modifications permitted and with its sealing washer in place. The machining of the head to take this De-Com valve can only be carried out by Tal-Ko on new supplied EeziStart engines or new supplied EeziStart cylinder heads. It is not permissible to machine and fit these EeziStart De-Com valves to old used heads. It is permissible to cut the last 2 blocks off on 6H Fin Rubber to allow fitment of this EeziStart De-Com Valve.

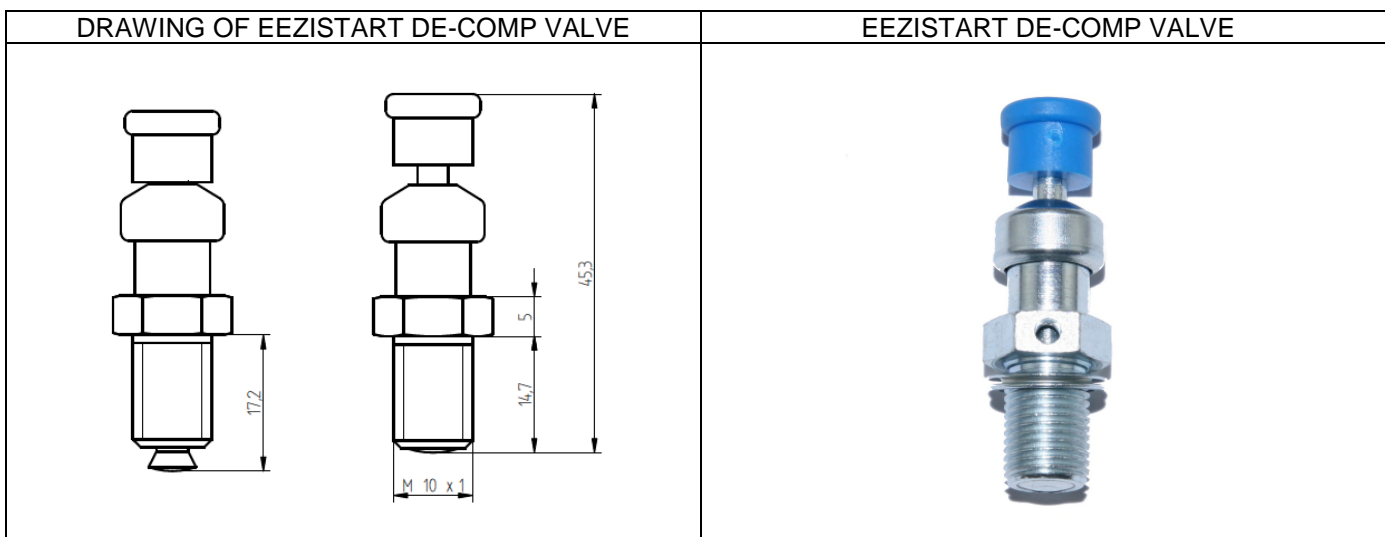

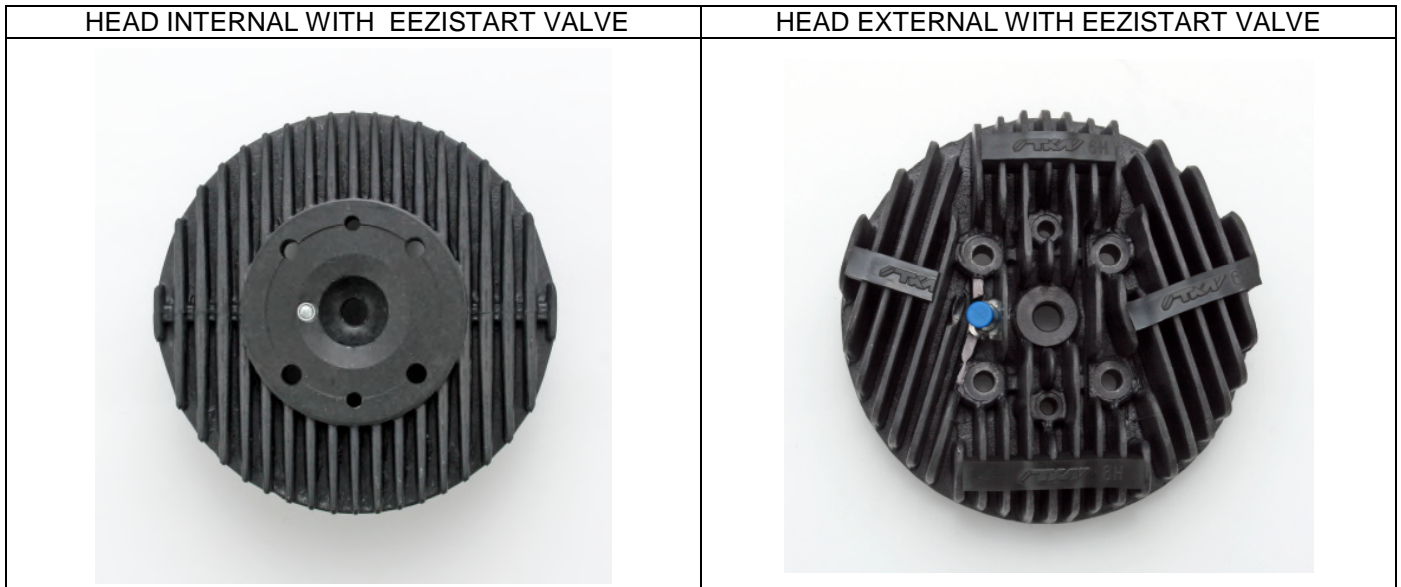

THREAD REPAIRS: It is permitted to use Helicoil type & Time-Sert thread replacements to repair all stripped threads on engine fixings on the crankcase and cylinder barrel. On the spark plug threads only a Helicoil type thread repair is permitted. Any other type of repair or insert is prohibited. Such repairs must not be used to derive any benefit other than rectification of damage. In the case of the spark plug thread, no portion of the helicoil may protrude outside of the normal thread area. The coil must be inserted to the full length of the original thread and only one continuous coil to be used per repaired thread. In all cases the size of the repaired threads must remain as standard. On the carburettor it is permitted to repair the non metric threads with M3 or M4 threads providing they do not perform any other function.

FIN RUBBERS: The use of purpose designed TKM fin rubbers is mandatory. All new engines are fitted with noise reducing fin rubbers as supplied by Tal-Ko. These comprise 10 special rubbers all with TKM logo and either marked H or B to indicate whether for head or barrel. Competitors must use a full set of these rubbers, which may be fitted to older engines. The use of more than 10 rubbers is allowed but not advised. Only TKM rubbers permitted. Where fins have become broken or no longer exist due to fitment of the optional EeziStart De-Com Valve on an engine it is permitted to remove excess sections of the rubbers at this point.

TKM INDUCTION AIR BOX: It is mandatory to use the TKM induction air box assembly complete with filter as supplied by Tal-Ko. The latest incorporates a carburettor mounting flange with TKM logo. This new air box assembly complete must not be modified except for the drilling of a small hole in the bottom securing mounting lug found at base of main air box body. This hole must not allow air to enter air box and is only to be used for fixing purposes. It is permissible to use either a cable tie/nut & bolt/etc through this mounting / securing lug hole. It is also permissible to add to one of the chassis tubes a single mounting clamp for connection to this securing mounting lug or to use a cradle support with securing ties around main noise box body. At all times the large TKM logo on air box must be visible.

The air box body must have the large TKM logo and must at all times have the two black coloured induction pipes with nominal 23mm I/Ds firmly clipped in their correct position. No other pipes permitted and no modifications allowed. The twin density bonded filter must be as supplied by Tal-Ko, externally black in colour. No other coloured or models of filters permitted. It is not permitted to paint the filter with black or other colour. The Tal-Ko supplied carburettor mounting flange with TKM logo is the only flange permitted and must not be modified. The use of any sort of tuner name, identification or colouring on the air box (other than TKM) is not permitted. The original style back plate gasket must still be used between the carburettor and the new aluminium mounting flange.

EXHAUST SYSTEM COMPLETE: Must be as supplied for engine and manufactured by or for Tal-Ko with TKM logos. No modifications allowed. On all 100cc & 115cc BT82 engines, except TAG versions, the smaller nominal 40mm O/D TKM exhaust manifold together with matching exhaust flex, flex ring and exhaust must be used. On BT82 TAG engines **only**, the larger nominal 45mm O/D TKM exhaust manifold together with matching exhaust flex, flex ring and exhaust must be used. It is permissible on both systems to change the lengths of the exhaust flex. Fitment of the exhaust flex ring in both systems is optional. It is permitted to externally paint the TKM manufactured exhaust silencer provided that only black paint is used and that the original TKM logo is still visible. It is expressly prohibited to use any other coating or plating or to use any colour other than black. It is not permitted to carry out extensive polishing and any accompanied weight reduction processes.

BT820394

As part of TKM's commitment to noise reduction, it is mandatory to use the exhaust end can provided by Tal-Ko and marked with the TKM logo which must be fitted with the three large exhaust exit holes 180 Degrees opposite to the main exhaust tailpipe exit. It is also mandatory to use effective heatproof webbing or similar sleeve material wrapped around the exhaust flex to help reduce noise. Make is free. It is permitted to fit additional silencing where required by Motorsport UK or local club regulations, provided that the original complete TKM equipment is still used in unmodified form.

V CLUTCH: Only permissible clutch assembly complete is the one supplied for engine as manufactured by or for Tal-Ko with no modifications and the TKM logo stamped on all of the three clutch shoe outer faces. It is not permissible to reline the clutch shoes or add substances to either the shoes or drum. Only clutch springs as supplied and manufactured by or for Tal-Ko with no modifications can be used. The clutch must be triggered and make the kart and driver move forward by 4500 rpm maximum. The clutch must be in direct drive (and 100% engaged) by 7500 rpm maximum. Only V clutch sprockets as supplied and manufactured by or for Tal-Ko with no modifications with the TKM logo stamped on outside face can be used.

HORSTMAN CLUTCH: Must be as supplied for engine by Tal-Ko with no modifications with the TKM logo marked on 10 & 11 tooth sprocket drum & fixed pressure plate. Green retaining spring nuts set at 6.25mm +-0.25mm measured from top of retaining nut to drive hub face. Spring type: (1.96mm Max Wire O/D) X (12.82mm Max Spring Total Length). Engine starting by use of remote electric starter only. The use of the TKM stamped clutch safety cover is mandatory when Horstman clutch is fitted.

DIRECT DRIVE CHAIN SPROCKETS: 9T, 10T & 11T TKM logo stamped and manufactured by or for Tal-Ko sprockets only permitted.

IGNITION COIL MOUNTING PLATE: Must be as originally supplied for engine and manufactured by or for Tal-Ko in unmodified form with the TKM logo stamped on outside face and must always be in position.

MOTOPLAT IGNITION SYSTEM (Non Tag): The Motoplat 9600903-1 originally supplied ignition system complete, although no longer available, is still permitted with no modifications or additional balancing.

MOTOPLAT IGNITION TIMING (Non Tag): Can be set between **2.0mm to 3.0mm BTDC**.

NGK PLUG CAP (Non Tag): The use of the unmodified NGK LB05EMH with built in resistor, red coloured plug cap as supplied for engine is mandatory on all non TAG engines.

PVL IGNITION SYSTEM (Non Tag): Must be as supplied for engine by Tal-Ko with no modifications. It is permitted to repair broken ignition wires providing original type connectors are used. The following components coil & rotor must have the TKM logo present. To only be used on non TAG engines.

ITEM	MAKE / MARKINGS	COLOUR	TKM LOGO
Plug Cap	NGK LB05EMH	Red	Not Present
Coil	PVL 105 458	Black	Stamped & Printed
Rotor	PVL 951	N/A	Stamped
Stator	PVL 1056	Black	Not Present

PVL IGNITION TIMING (Non Tag): Can be set between **1.5mm BTDC to 2.1mm BTDC**.

TAG PVL IGNITION SYSTEM: Items listed below in box must be as supplied for engine by Tal-Ko with no modifications. The following components where indicated below must have the TKM logo present. It is permissible to seal any connections to aid water-proofing. Repairs and modifications to the plugs and wiring looms are permitted.

ITEM	MARKINGS	COLOUR	TKM LOGO
Plug Cap	PVL 401 222	Black	Not Present
Coil	PVL 682 114	Black	Stamped & Printed
Rotor	PVL 682 900	Black	Not Present
Stator	PVL 682 810	Black	Not Present
CDI Box	PVL 682 242	Black	Stamped & Printed
Solid State Relay	PVL 682 301	Black	Not Present
Solid State Relay (Alternative)	PVL 682 302	Black	Not Present
Driver Control Unit	PVL 682 350	Black	Not Present
Ignition Module	PVL 683 150	Black	Stamped & Printed
Stator	PVL 683 850	Black	Not Present
Rotor	PVL 683 900	Black	Not Present

BT820394

The new style PVL Ignition Module, Stator & Rotor offer no performance gain but improve reliability. A simplified and more robust PVL wiring loom, on / off push buttons and starter lead connection is available to match the new style PVL 683 system. This new style PVL ignition system is now a standard fitment on all new TAG specification engines. The new system may also be used on all older TAG specification engines.

TAG PVL IGNITION TIMING: Can be set between **3.00mm to 3.60mm BTDC**.

TAG PVL PLUG CAP: The use of the unmodified PVL 401 222 with built in resistor, black coloured plug cap as supplied with engine is mandatory. This plug cap can **only** be used on the TAG version BT82 engine.

TAG DRIVER PUSH BUTTONS: It is permissible to use other types of stop start switches other than the PVL ones supplied with the engine. Position is free providing it conforms to Motorsport UK regulations. With the standard PVL buttons or the PVL new style ones as supplied it is advised they are used in conjunction with either the TKM supplied steering wheel mounting bracket or the round holes in spoke of steering wheel. It is permissible to seal any connections to aid water proofing as well as the repairs to broken wiring including replacement connections.

TAG BATTERY MOUNT: It is permissible to use other types of battery mounts and covers other than the TKM one supplied with the engine. Modifications can be carried out to both the mount and its plastic cover to aid fitment to the kart, and the PVL components and battery. If the TKM mount & cover is used it must be raced complete with the plastic TKM provided cover. It is permissible to seal any connections to aid water proofing as well as the repairs to broken wiring including replacement connections to suit. It is permissible to drill additional holes both in the battery mounting plate and the plastic cover for the fitment of additional security fittings such as cable ties and water proofing or other.

Please Note: The following components can be fitted anywhere on the kart providing it conforms to Motorsport UK regulations:-

Battery, PVL CDI Box, PVL Fuse, PVL Solid State Relay, PVL Driver Control Unit & Push Buttons.

The new style PVL Ignition Module must be mounted on the front of the engine as supplied by Tal-Ko.

The only items which must be used on both the old and new style systems are:

Old Style: ***PVL Plug Cap, PVL HT Lead, PVL Coil, PVL Rotor, PVL Stator and the PVL CDI box.***

New Style: ***PVL Plug Cap, PVL HT Lead, PVL Ignition Module, PVL Rotor & PVL Stator.***

It is not permitted to use/mismatch the rotors & stators from the old 682 system with the new 683 system.

Various items listed as not mandatory such as ***Relays, Fuses and PVL wiring loom*** may be completely removed from the kart.

When using a TAG specification engine it is mandatory to always have the full system in place as applicable and connected to enable the starter to be used to start the engine. An external hand-held starter may be used to start the engine in case of any problem, but at any time before or after a race the driver may be required to demonstrate that the starter system with its on-board battery is fully fitted and functioning.

TAG BATTERY: Batteries are free but must comply with Motorsport UK regulations.

TAG WIRING LOOM, EXTENSION LEAD & STARTER LEAD: All are free and can be replaced with non PVL.

TAG STARTER MOTOR: Only permissible starter motor is the one supplied for engine by Tal-Ko with no modifications and with the TKM logo present on mounting face casting. It is permissible to drill and lock-wire the 2 off M5 cap head motor housing bolts if required.

TAG STARTER MOTOR HOUSING: Must be as supplied for engine and manufactured by or for Tal-Ko with no modifications with the TKM logo cast on outside.

TAG STARTER MOTOR BENDIX GEAR: Must be as supplied for engine by Tal-Ko with no modifications.

TAG STARTER RING GEAR: Must be as supplied for engine and manufactured by or for Tal-Ko with no modifications having 66 teeth.

Appendix 1 – Officially Sanctioned TKM Checking Tools

ITEM	PART NUMBER	PICTURE
HEAD GAUGE "STANDARD"	T001	
HEAD GAUGE "11 DEGREES"	T001/11	
HEAD GAUGE "13 DEGREES"	T001/13	
HEAD GAUGE "EXTREME"	T001/E	
HEAD GAUGE "SPARK PLUG"	T002	
MEASURING PLUG for Checking Head Volume	T003	
RADIUS GAUGE for Checking Head	T004	
FEELER GAUGE 0.25mm X 6mm	TFG025	

Appendix 1 continued – Officially Sanctioned TKM Checking Tools

ITEM	PART NUMBER	PICTURE
GAUGE for Checking "Exhaust Port Width"	T3EW	
GAUGE for Checking "Exhaust Port Height"	T4EHN	
GAUGE for Checking "Exhaust Port Bar Width"	T5EB	
GAUGE for Checking "Inlet Port Width"	T6IW	
GAUGE for Checking "Inlet Port Height" on CAST LINERS	T7IH	
GAUGE for Checking "Inlet Port Height" on CNC LINERS	T7IHCNC	
GAUGE for Checking "Transfer Port Width"	T8TW	
GAUGE for Checking "Transfer Port Width"	T9TW	
FIXTURE BLOCK for Dial Gauge	TFB	