

Kart Brake System Homologation – Inter & Cadet

Manufacturer	Simon Wright Racing Developments Ltd
Make	Wright
Model	Hydra

Valid for	Cadet <input checked="" type="checkbox"/>	Inter <input checked="" type="checkbox"/>
------------------	---	---

Valid from	01 January 2023	Valid until	31 December 2030
-------------------	-----------------	--------------------	------------------

This Homologation Form reproduces descriptions, illustrations and dimensions of the brake system at the point of homologation. The Manufacturer may only modify these within the limits set by the Motorsport UK regulations in force and with the written agreement of Motorsport UK.

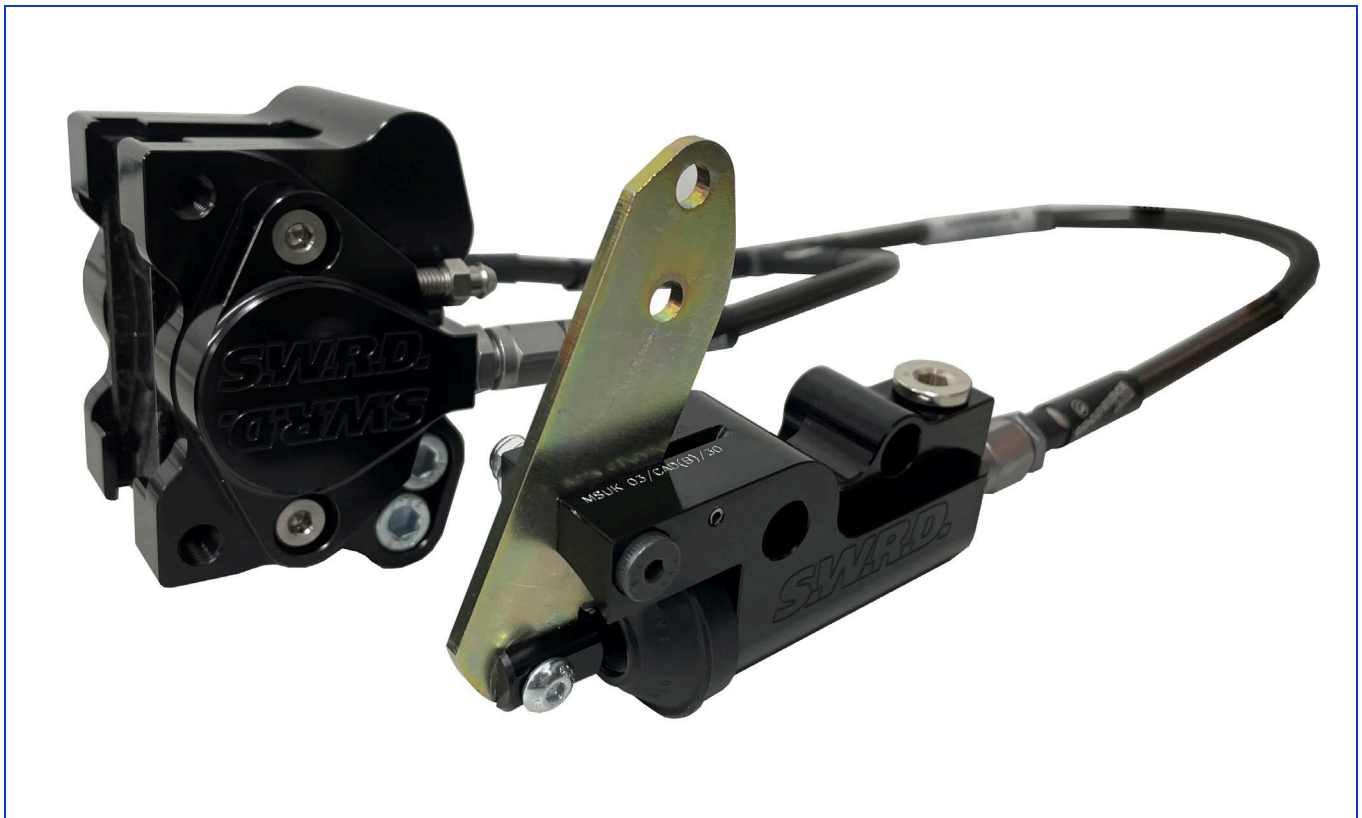

Photograph of the complete brake system

Signature and stamp of Motorsport UK

	Date: Date
	Signed by: Name
	Position: Position

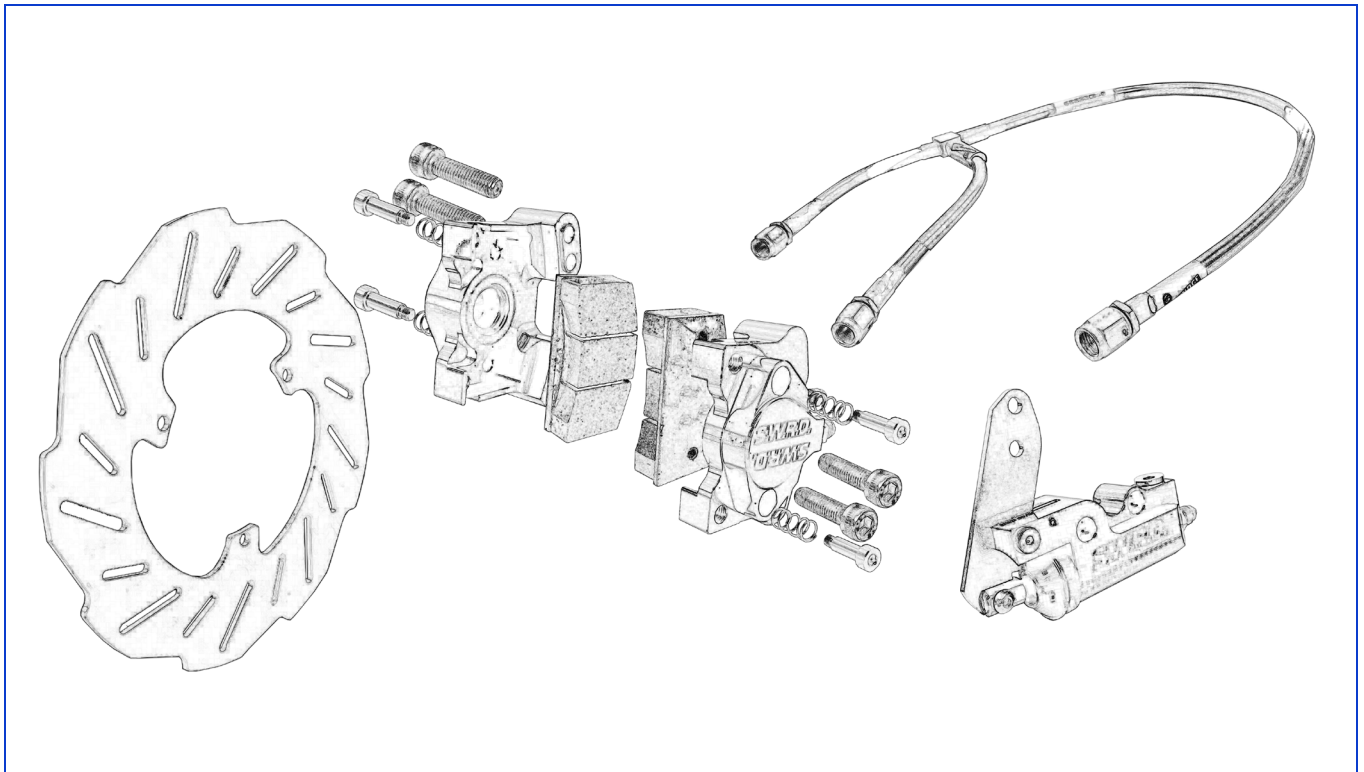
Technical drawing

Exploded technical drawing

Table 1 – Technical information

		Measurement	Tolerance / Remark
A	Number of master cylinders	1	-
B	Master cylinder bore	19.3 mm	-
C	Number of callipers	1	-
D	Calliper material	Aluminium	-
E	Number of pistons	2	per calliper
F	Calliper bore	32.0 mm	-
G	Number of pads	2	per calliper
H	Overall length of pad	73 mm	± 1.5 mm
I	Length of friction material	73 mm	± 1.5 mm
J	Height of friction material	13.5 mm	± 1.5 mm
K	Ventilated disc?	No	not permitted for Cadet
L	Thickness of new disc	3 mm	± 1 mm
M	External diameter of disc	185 mm	± 1.5 mm

Photos

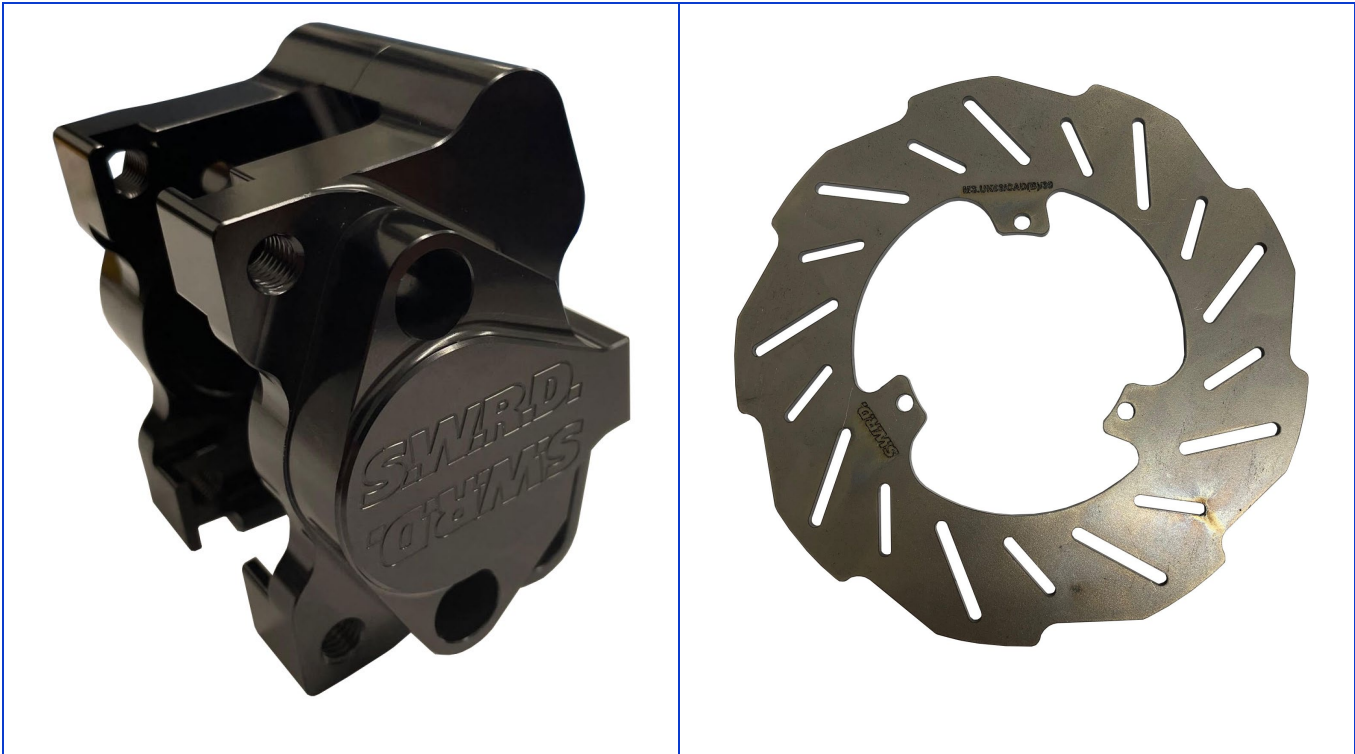

Photograph of brake calliper

Photograph of brake disc

Photos of homologation number markings



Master cylinder

Line

